

LRV System

Oleo has developed a modular Coupling and Anti-climbing system specially designed for the LRV market with standard head types.

All couplers are manually foldable.

The length of the coupler from car body to hinge and hinge to coupler face can be varied to suit each application.

Various options are available for the buff and draft (2 way) energy absorption depending on the requirements of the application.

- Gas Hydraulic absorber for higher speeds/load applications.
- Elastomeric energy absorber for medium speed/load applications.
- Stiff bar for low speed/low mass applications.

The Anti-climber system is designed to work together with the Coupling system to provide the optimum passenger safety in the event of an accident, and all Oleo products are fully configurable with Oleo's 1D Rail simulation software.

Oleo's anti climber ranges have been specifically designed to limit vertical movement even in offset impacts, and promote a controlled longitudinal stroke.

Applications

- Metro
- Light Rail
- Locomotive & Freight
- High Speed
- Mainline

Couplers

Type 330 coupler head
Foldable coupler

Albert coupler head
Foldable

Gas-hydraulic buff and draft
energy absorber

Elastomeric buff and draft
energy absorber

Stiff bar

Anti-climbers

Front or rear-mounted
non-reversible energy
absorption with
frontal beam

Reversible and 2 stage
non-reversible energy
absorption with
frontal beam

Product details

Standard range of Oleo couplers and Anti-climbing devices:

COUPLERS

- Customisable lengths.
- Manually foldable.
- Standard coupler heads.
- Optional Buff and Draft energy absorbers.
- Standard mounting bracket.
- Maximum Force range up to 400kN.
- All elastomeric and gas-hydraulic absorbers are tested by Oleo with validated mathematical models in accordance with EN15227. Available for Radioss and LS-Dyna finite element software.

• The system used by OLEO for the mathematical modelling of crash scenarios is approved by a European Rail Authority as being accurate, appropriate and properly controlled.

• Standardised design for reduced manufacturing lead-time and lower cost.

ANTI-CLIMBERS

• Deforming tube technology for improved crash performance (low force, high force and multi stage devices available).

• Standard Anti Climber head profile and Mounting Plate design.

Product advantages

• Modular range of Coupler and Anti-climber options to suit LRV project requirements.

COUPLERS

- Customisable lengths
- Performance of Gas Hydraulic absorber can be fully optimised with Oleo 1D Rail at no additional cost.
- Low mass designs and high energy absorption for optimised passenger protection.
- Maintenance free between major train overhaul periods.
- Standardised modular design with clamp connections for ease of service.

ANTI-CLIMBERS

- Performance can be fully optimised with Oleo 1D Rail at no additional cost.
- Controllable and predictable deforming forces across the complete stroke.
- Near 100% energy absorption efficiency.
- Standard mounting options for ease of customer selection.
- Designed to withstand vertical offsets ($\pm 40\text{mm}$ from axis).

LRV coupler specifications

Foldable coupler

Type 330 head, buff and draft energy absorber (Gas-hydraulic or Elastomeric)
 Mass - 146 kg typ

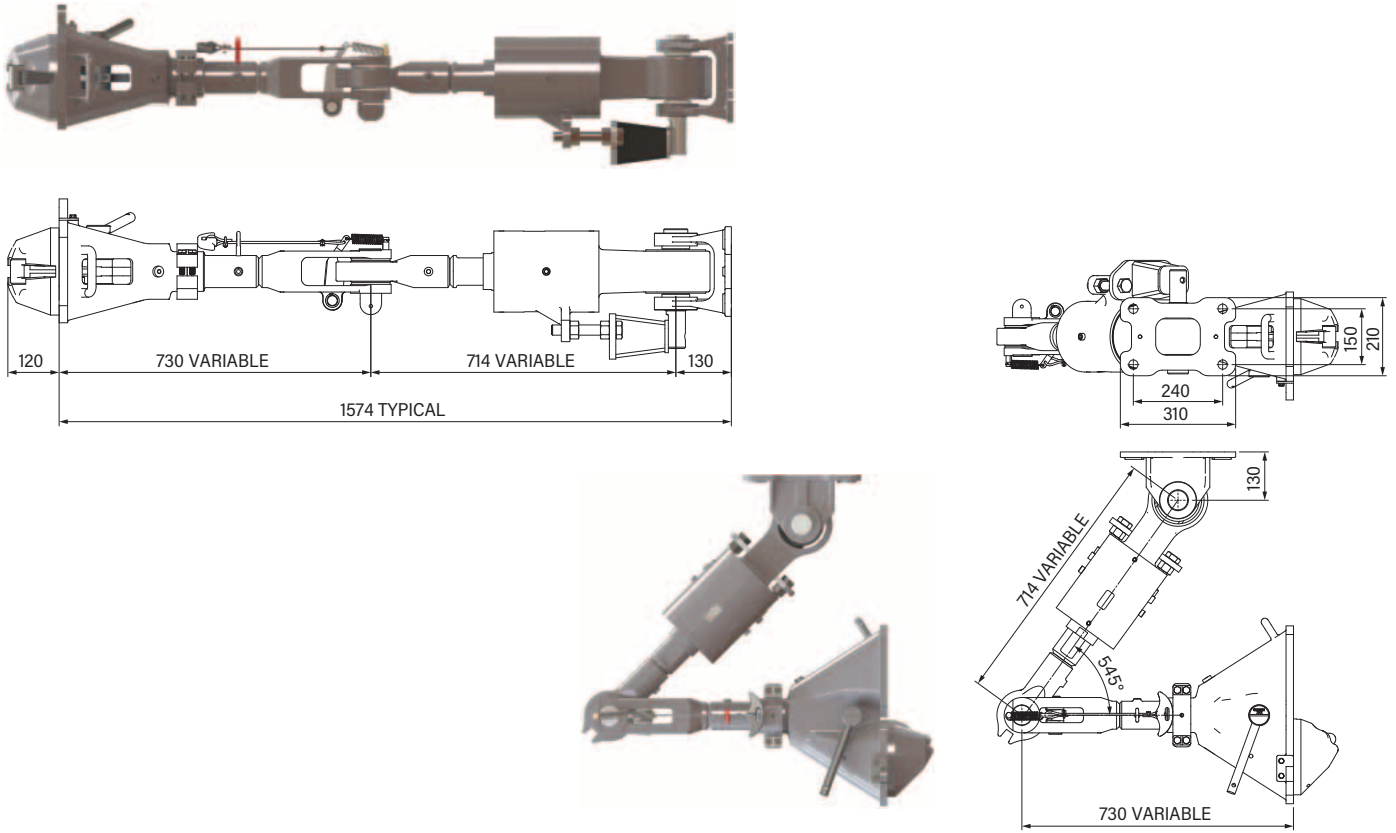

Albert coupler

Albert head, stiff bar
 Mass - 77 kg typ

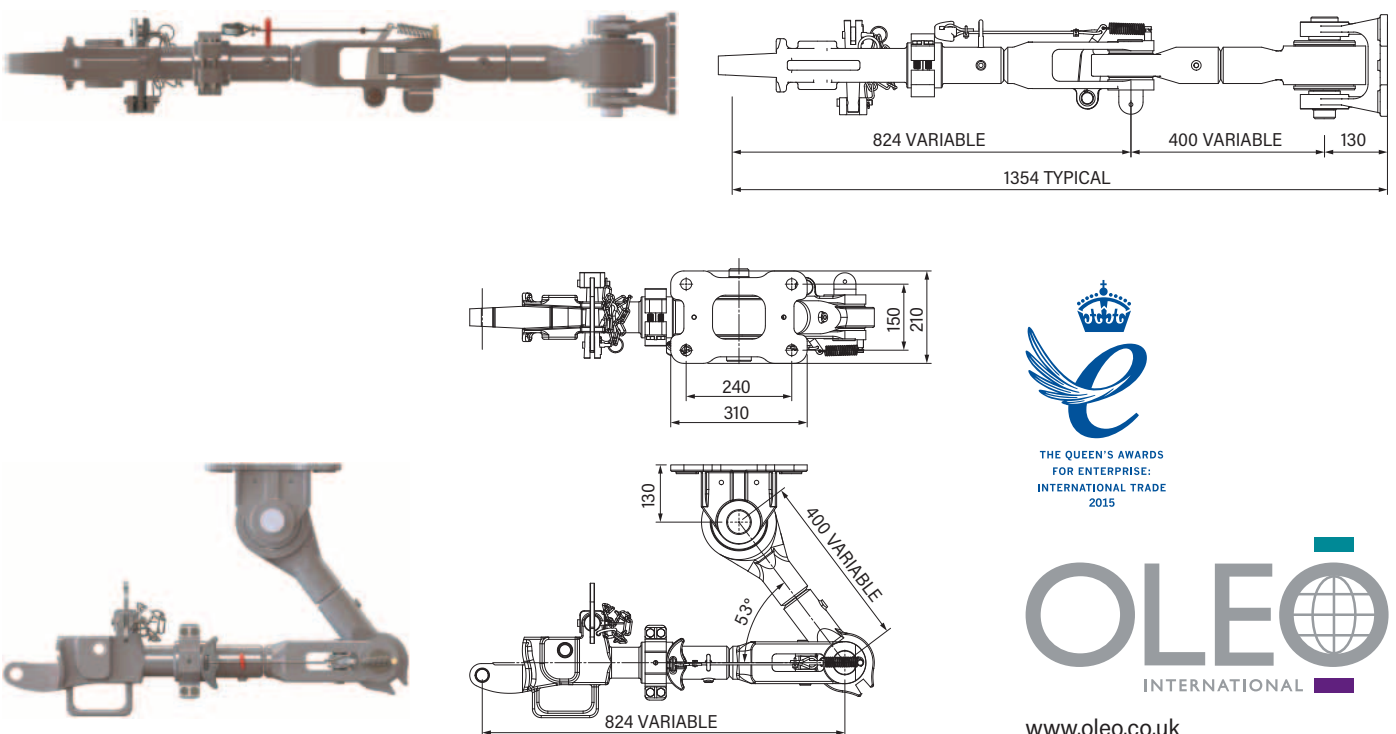

www.oleo.co.uk
 www.oleo.cn
 www.oleoinc.com