



## LB SERIES INSTALLATION GUIDE



ELEVATOR BUFFERS

LB 16-40

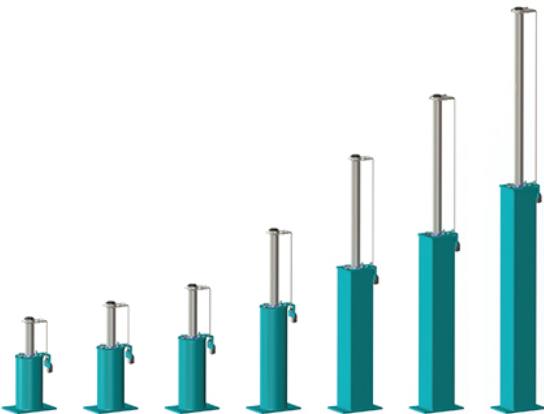

INSTALLATION GUIDE



## 1 SCOPE OF DELIVERY

Oleo buffers are supplied with a standard finish suitable for dry conditions (finished Oleo Green primer). The standard finish is not suitable for wet, corrosive conditions. Special finished buffers are available on request.

**Oleo LB buffers are supplied without oil.**

Should there be any discrepancies contact Oleo International before proceeding.

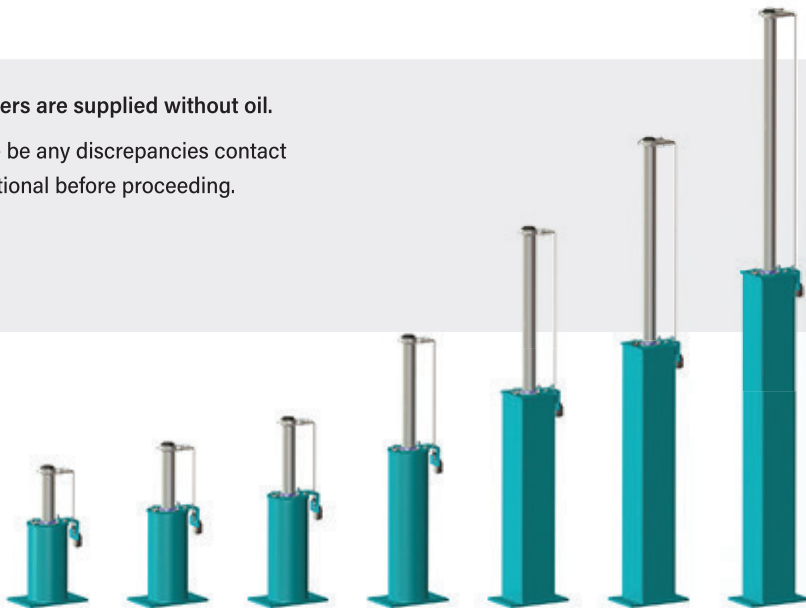

## 2 INDICATION OF USE

Environmental temperature acceptable conditions -15°C to 70°C.

### ! WARNING

The Oleo LB elevator buffer is supplied containing compressed gas; the plunger is held in the fully compressed condition during transportation by means of a bolt, this should not be removed until the buffer is in its final installed position.

### 3 HANDLING

When handling LB buffers ensure your regional health and safety laws are adhered to.

Figure 1

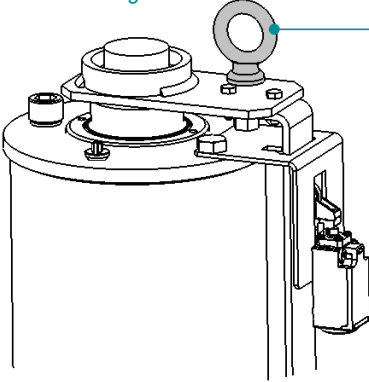

Use the Eye Bolt when lifting Oleo LB buffers, shown in *Figure 1*.

Figure 2

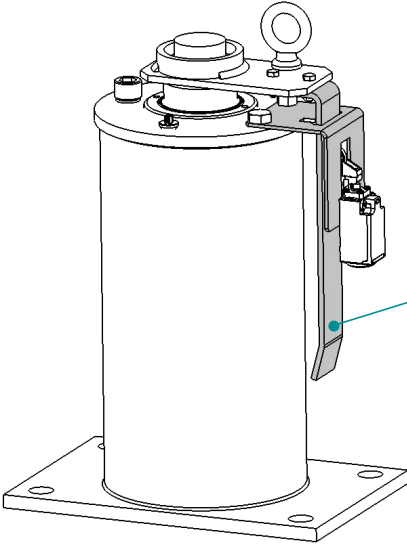

#### ⚠ WARNING

DO NOT lift buffer with the striker or switch bracket shown in *Figure 2*.

Avoid contact as this may cause damage.

Always confirm the weight of the buffer to be lifted and ensure that a suitable lifting method is used.

## 4 BUFFER WEIGHTS

### LB RANGE

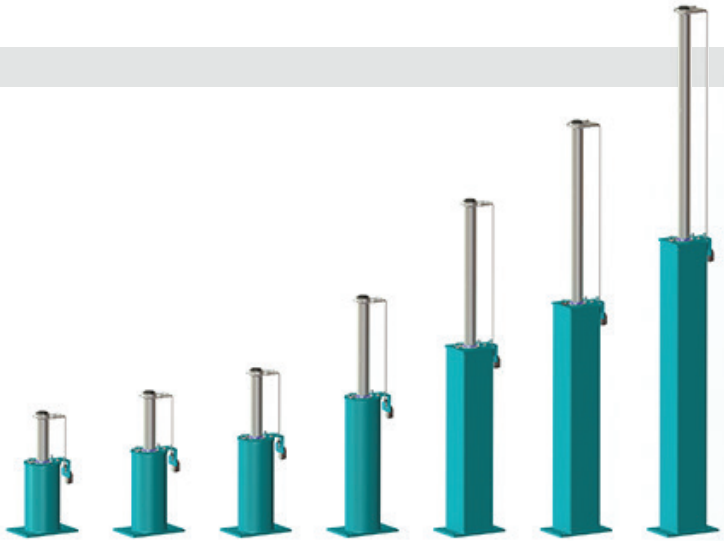

Buffer Model	LB 16	LB 18	LB 20	LB 23	LB 25	LB 32	LB 35	LB 40
Without Oil								
kg	25.54	28.12	30.96	35.86	40.14	54.93	65.46	80.69
lbs	56.31	61.99	68.26	79.05	88.49	121.1	144.3	177.9
When Filled with Oil								
kg	29.31	33.03	36.80	43.30	48.94	72.53	87.02	108.4
lbs	64.61	72.82	81.14	95.45	107.9	159.9	191.8	239.0

## 5 BUFFER INSTALLATION PROCEDURE

Ensure the buffer has been secured into its installation position.

Oleo recommends a bolt size M16 for fixing and all four fixing positions are used.

Ensure this area at the base of the buffer is supported (shown in *Figure 3*).

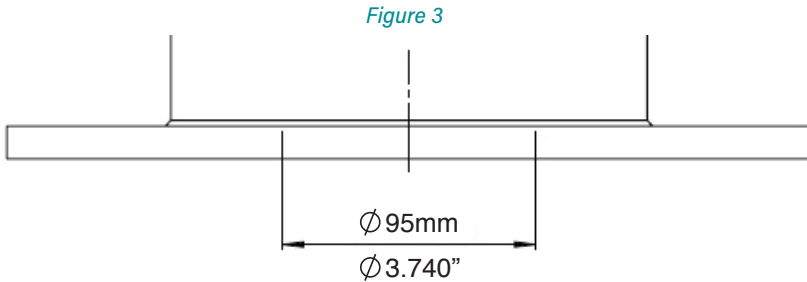

At this point the buffer is still compressed in its transportation state, now the buffer can be released by removing the eye bolt. The following is the recommended removal procedure.

For a controlled release, lower the elevator car (or equivalent) onto the buffer leaving the eye bolt exposed. This mass must be at least equivalent to the minimum mass of the specified buffer.

Minimum mass of the buffer shown in the table below:

Buffer Model	<b>LB 16</b>	<b>LB 18</b>	<b>LB 20</b>	<b>LB 23</b>	<b>LB 25</b>	<b>LB 32</b>	<b>LB 35</b>	<b>LB 40</b>
Min. Mass								
kg	500	500	500	500	500	700	1000	1000
lbs	1102	1102	1102	1102	1102	1543	2205	2205

## 5 BUFFER INSTALLATION PROCEDURE (Continued)

### ! DANGER

Now to release the plunger. DO NOT stand over the plunger when releasing.

To release the plunger, undo the eye bolt. See *Figure 4*.

Discard transportation eye bolt and spacer shown in *Figure 4*.

If used, remove the elevator car (or equivalent) and this will control the recoil of the buffer.

After periods of being held in the compressed state during transportation and storage, the plunger may require assistance to initially extend. This should be done using a rubber dead blow mallet to tap the underside of the buffer head (GREEN in *Figure 4*) at 90 degree intervals until the plunger extends.

Once fully extended and stroked the buffer will perform as designed.

Buffers are to be fitted vertically parallel to guide rail +/- 5mm.

*Figure 4*

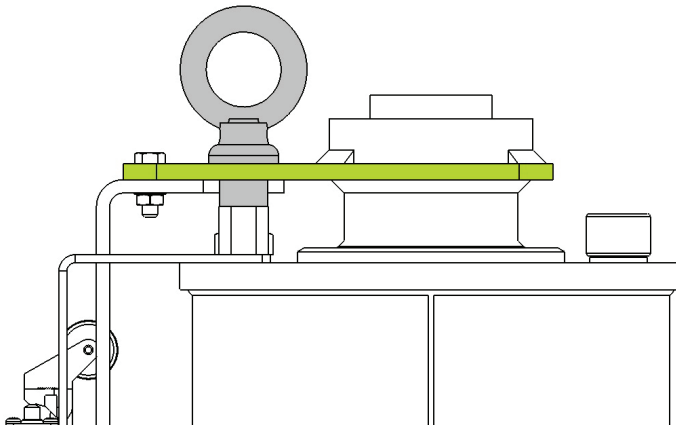

## 6 OIL SPECIFICATION

The oil must conform to the specification on the buffer data plate –  
 ISOVG68 : SG.88/90 at 15°C : hydraulic.  
 Pour Point : 18°C or lower. Viscosity index 75 or higher

### ⚠ CAUTION

Take care when handling the oils. Observe the oil manufacturer's recommendations.

The oil volume guide can be found in table below:

Buffer Model	LB 16	LB 18	LB 20	LB 23	LB 25	LB 32	LB 35	LB 40
Approximate Oil Volume								
Litres	4.62	5.58	6.64	8.45	10.0	20.0	24.5	31.5
US Gallons	1.22	1.47	1.75	2.23	2.64	5.28	6.47	8.32

### MINIMUM & MAXIMUM

The oil level needs to be between the Minimum and Maximum marks indicated on the dipstick as shown in *Figure 5* for LB16 – LB25 or *Figure 6* for LB32 – LB40.

*Figure 5*

LB16 – LB25 Dipstick

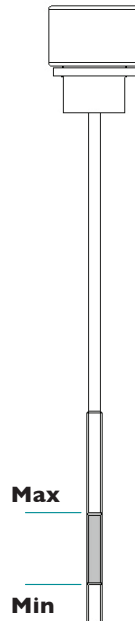

*Figure 6*

LB32 – LB40 Dipstick

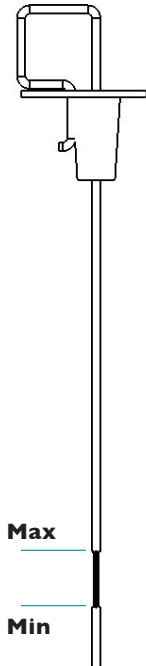

## 7 OIL FILLING PROCEDURE - LB16 to LB25

### ! NOTICE

The buffer must be vertical and fully extended before filling with oil.

### ! CAUTION

Take care when handling the oils. Observe the oil manufacturer's recommendations.

- 1 Unscrew the airscrew, remove from the buffer and keep safe. (GREEN in *Figure 7*).
- 2 Unscrew the dipstick, remove from the buffer and keep safe. (GREY in *Figure 7*).
- 3 Gradually fill the buffer with oil until the oil level is visible between the minimum and maximum levels on the dipstick (indicated on *Figure 5*).
- 4 Allow the buffer to stand for a minimum of 30 minutes.
- 5 Re-insert the dipstick **DO NOT** screw down.
- 6 Remove dipstick and inspect level. The oil level needs to be between the minimum and maximum marks indicated on the dipstick as shown in *Figure 5*.
- 7 Once oil level is correct replace airscrew and securely fasten.
- 8 Once oil level is correct replace dipstick and securely fasten.

*Figure 7*

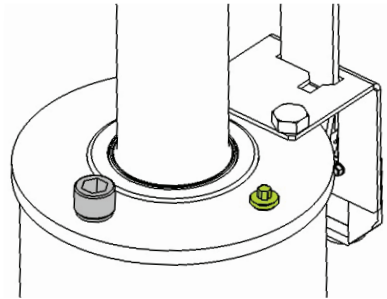

The oil must be within the correct operating range for the buffer to perform correctly. If further oil is required after checking repeat steps 1-8.

### ! WARNING

DO NOT overfill past the maximum dipstick mark. If this occurs, then oil must be removed from the buffer.



## 8 OIL FILLING PROCEDURE - LB32 to LB40

### ! NOTICE

The buffer must be vertical and fully extended before filling with oil.

### ! CAUTION

Take care when handling the oils. Observe the oil manufacturer's recommendations.

- 1 Unscrew the air plug, remove from the buffer and keep safe. (GREEN in *Figure 8*).
- 2 Remove the dipstick from the buffer and keep safe. (GREY in *Figure 8*).
- 3 Remove the rubber plug, shown in *Figure 9* from the dipstick and discard.
- 4 Gradually fill the buffer with oil until the oil level is visible between the minimum and maximum levels on the dipstick (indicated on *Figure 6*).
- 5 Allow the buffer to stand for a minimum of 30 minutes.
- 6 Re-insert the dipstick and clip down (indicated in *Figure 10*).
- 7 Remove dipstick and inspect level. The oil level needs to be between the minimum and maximum marks indicated on the dipstick as shown in *Figure 6*.
- 8 Once oil level is correct replace air plug and securely fasten.
- 9 Once oil level is correct replace dipstick and securely fasten. (indicated in *Figure 10*).

The oil must be within the correct operating range for the buffer to perform correctly.

If further oil is required after checking repeat steps 1-9.

*Figure 8*

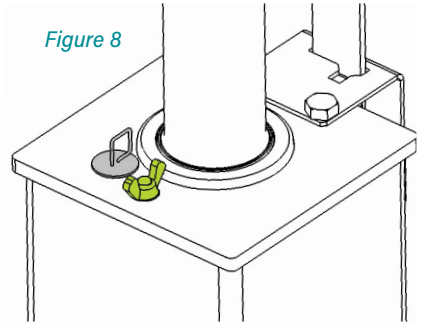

*Figure 9*

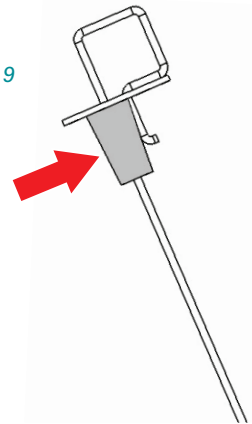

### ! WARNING

DO NOT overfill past the maximum dipstick mark.

If this occurs, then oil must be removed from the buffer.

## 9 OIL CHECKING PROCEDURE - LB16 to LB25

The oil level must be correct and needs to be checked using the following procedure:

*Figure 5*

LB16 - LB25 Dipstick

- 1 Unscrew the dipstick and remove from the buffer. (GREY in *Figure 7*).
- 2 Wipe dipstick clean.
- 3 Re-insert the dipstick **DO NOT** screw down.
- 4 Remove dipstick and inspect level. The oil level needs to be between the maximum and minimum marks indicated on the dipstick as shown in *Figure 5*.
- 5 Once oil level is correct replace dipstick and securely fasten.

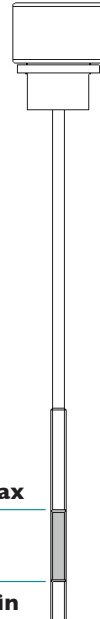

The oil must be within the correct operating range for the buffer to perform correctly.

If further oil is required after checking refer to Oil Filling Procedure *Section 7*.

### ! WARNING

DO NOT overfill past the maximum dipstick mark.  
If this occurs, then oil must be removed from the buffer.

## 10 OIL CHECKING PROCEDURE - LB32 to LB40

The oil level must be correct and needs to be checked using the following procedure:

- 1 Unclip the dipstick and remove from the buffer.
- 2 Wipe dipstick clean. (GREY in [Figure 8](#)).
- 3 Re-insert the dipstick and clip down.
- 4 Remove dipstick and inspect level.  
The oil level needs to be between the maximum and minimum marks indicated on the dipstick as shown in [Figure 6](#).
- 5 Once oil level is correct replace dipstick and clip down. (indicated in [Figure 10](#)).

The oil must be within the correct operating range for the buffer to perform correctly.

If further oil is required after checking refer to Oil Filling Procedure [Section 8](#).

*Figure 6*

LB32 - LB40 Dipstick

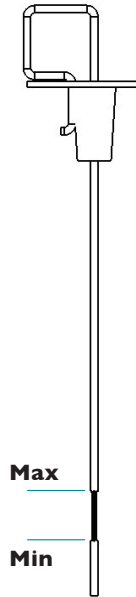

*Figure 10*

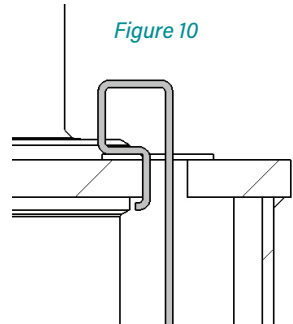

### ⚠ WARNING

DO NOT overfill past the maximum dipstick mark.  
If this occurs, then oil must be removed from the buffer.



## 11 FINAL COMMISSIONING

Oleo recommends the final 7 step process is followed prior to commissioning:

- 1 Ensure oil level is correct.
- 2 Ensure striker is vertically aligned to +0.5 mm.
- 3 Complete electrical connections to the limit switch.

### ! WARNING

As a safety critical component, buffers should not be installed without a switch.

- 4 Compress the buffer at slow speed across the full working stroke then allow to recoil.
- 5 Allow the oil to settle for 30 minutes then recheck oil level – see [Section 9](#) for LB16 – LB25 or [Section 10](#) for LB32 – LB40
- 6 Finally, impact the buffer at the full rated speed of the elevator.
- 7 Complete final checks of oil level and the buffer is at correct working height.

### ! NOTICE

CHECK: The maximum overall height against table below +0/-9mm of the figure stated.

Buffer Model	LB 16	LB 18	LB 20	LB 23	LB 25	LB 32	LB 35	LB 40
Extended Height								
m	0.6166	0.7229	0.8389	1.0379	1.2109	1.7059	2.1079	2.6929
in	24.276	28.461	33.028	40.862	47.673	67.161	82.988	106.020

### ! NOTICE

If the buffer has not returned to the fully extended position (determined by measuring overall height) contact Oleo International.

## 12 MAINTENANCE

Oleo recommends the following be carried out every 12 months from installation:

- 1 Clean away debris and dirt from around the plunger and switch.
- 2 Check the oil level is correct.
- 3 Compress the buffer across its full working stroke.
- 4 After the compression, ensure the buffer has returned to its correct working height and visually check for any damage. See correct working height in table in [Section 11](#).

Ensure regional jurisdictions and laws for maintenance are adhered to.

**OLEO INTERNATIONAL**

Grovelands  
Longford Road  
Exhall  
Coventry  
United Kingdom  
CV7 9NE

**E** sales@oleo.co.uk  
**T** +44 (0)24 7664 5555  
**F** +44 (0)24 7664 5900  
**W** oleo.co.uk

**OLEO BUFFERS SHANGHAI  
COMPANY LTD**

Plant A15 Xinfei Garden  
No.3802 Shengang Road  
Songjiang  
Shanghai  
201612 China

**E** sales@oleo.cn  
**T** +86 21 6776 0688  
**F** +86 21 6776 0689  
**W** oleo.cn



EUROPE



CANADA/USA



CHINA



KOREA



RUSSIA



ALTERNATIVE LANGUAGE INSTALLATION INSTRUCTIONS ▶



This Installation Guide can be found in the following languages;

**Français**  
**French**

**Deutsche**  
**German**

**Español**  
**Spanish**

**Portuguese**  
**Portuguese**

**中文**  
**Chinese**

**Brasileiro**  
**Brazilian**

**Italiano**  
**Italian**

**Русский**  
**Russian**

**한국어**  
**Korean**

**日本語**  
**Japanese**

Please visit:

<https://www.oleo.co.uk/downloads/elevator-installation-booklets>