

Automatic coupler with electrical head, anchor with centring, support and integral shear off device.
 Type 330 or Type 10 Coupler head.
Oleo Sentry energy absorber with buff, draft and crash functions.

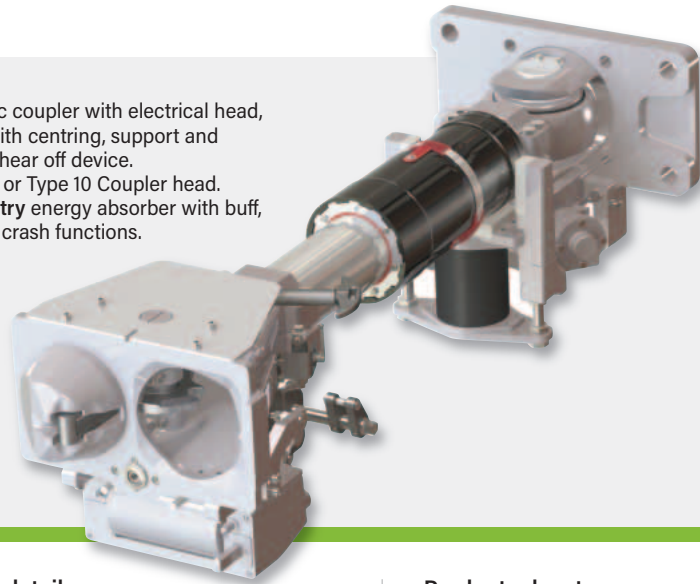

Automatic Coupler

Oleo has developed a modular range of Gas Hydraulic Couplers for the Metro market with standard head types including Type 330 and Type 10.

The couplers are fitted with the Oleo Sentry energy absorption system with strokes and load ratings to suit the requirements of Metro applications.

All Oleo couplers have been extensively tested to reduce Non-recurring costs and lead times – detailed test reports to be available with product supply.

The Automatic coupler is designed to work together with the Semi-permanent (Intermediate) couplers and Anticlimbers (if fitted) to provide the optimum passenger safety in the event of an accident, and all Oleo products are fully configurable with Oleo's 1D Rail simulation software.

Integration of the Sentry Energy Absorber into the coupler system removes the need for heavy draft springs and draft housings.

By reducing the variety and complexity, this can allow for lower project costs per train coupling system whilst also offering higher coupling speeds, significant weight savings and reduced life cycle costs.

Product details

Standard range of Oleo couplers:

- Optional Type 330 or Type 10 heads with pneumatic coupling/uncoupling (UC).
- Standard Pneumatic connections for MRP (Main Reservoir Pipe) and BP (Brake Pipe).
- Electrical heads with high-speed data transmission option 100Mbit.
- Modularised Buff, Crash and Draft energy capacity.
- Standardised car body interfaces.
- Maximum Force range up to 1200kN.
- Adjustable centring and support.
- Bracket with integral shear off connection.
- Fully customisable force/stroke characteristics at no extra cost.
- All couplers and energy absorption devices have been tested by Oleo with validated mathematical models in accordance with EN15227. Representative elements are available for Radioss and LS-Dyna finite element software.
- The system used by OLEO for the mathematical modelling of crash scenarios is approved by a European Rail Authority as being accurate, appropriate and properly controlled.
- Standardised design for reduced manufacturing lead-time and lower cost.

Product advantages

Oleo's Coupler Devices enable:

- Lower price per Train Set.
- Lower Life Cycle Costs.
- Weight saving.
- Faster Coupling Speeds.
- Reduced Potential Impact Damage.
- Increased Passenger Protection.

Performance optimisation at no cost with pre loads ranging from 40kN to 450kN.

Low mass design with higher recoverable energy absorption than any alternative solution.

Maintenance free between major train overhaul periods.

Standardised modular design with clamp connections for ease of service.

Applications

Metro



Light Rail



Locomotive & Freight



High Speed



Mainline



Automatic coupler specification

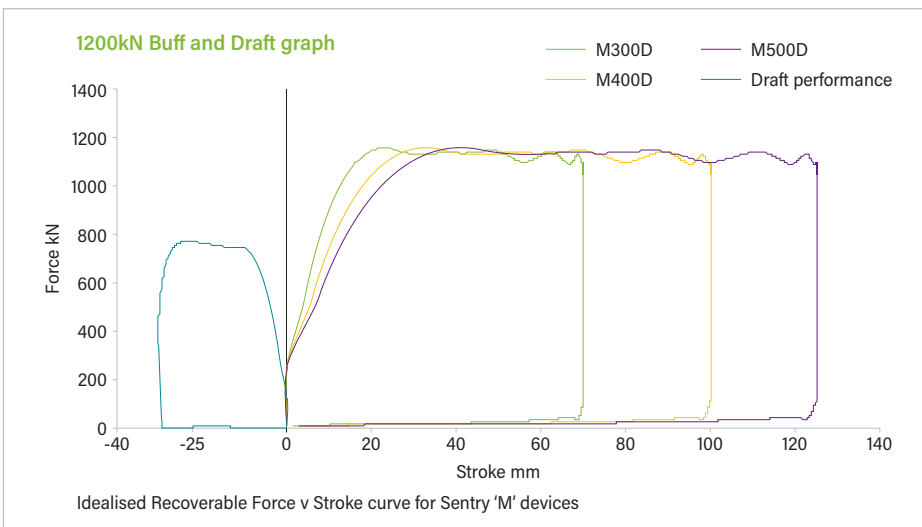
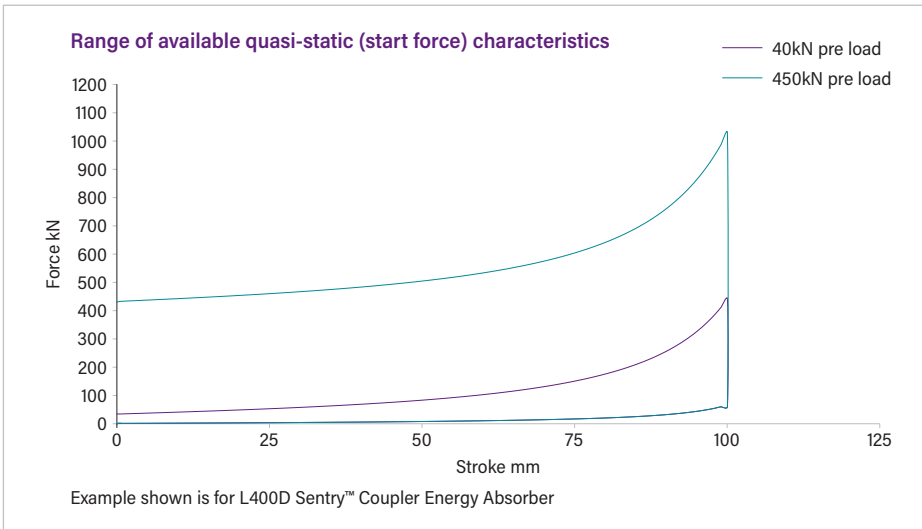
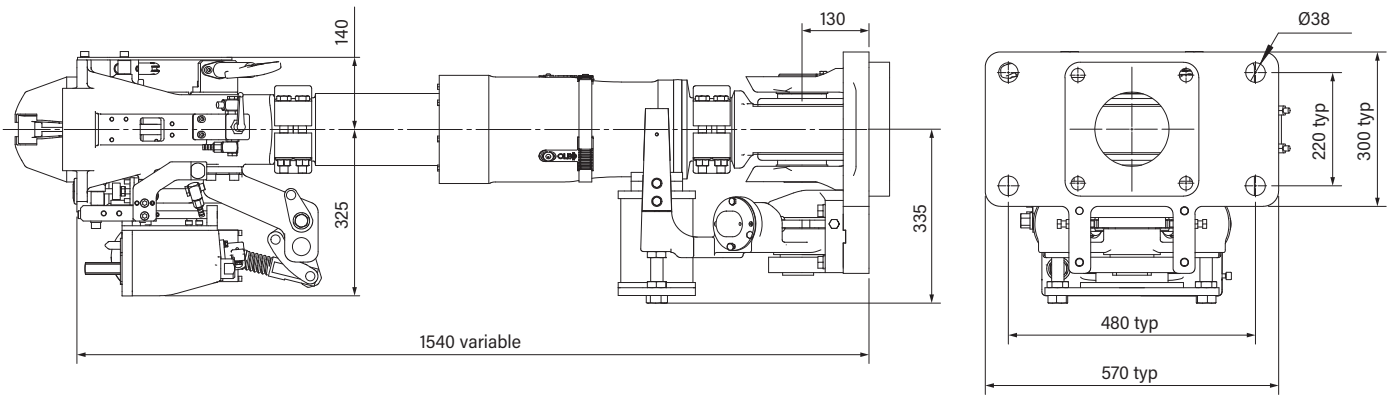

www.oleo.co.uk
www.oleo.cn
www.oleoinc.com